

Stock Horse of Wisconsin



S.H.O.W.

2011 Fall Ranch Competition At Idlewild Farm • Sturgeon Bay, WI

SATURDAY, OCTOBER 15th - 10:00 am

Trail (Youth & Adult divisions)

Stock Horse Pleasure (Youth & Adult divisions)

Reining (Youth & Adult divisions)

SUNDAY, OCTOBER 16th - 10:00 am

2-man Sorting (Youth & Adult divisions)

Separate youth/adult combined division...points do not count towards high point or year end awards

3-man Ranch Roping (Adult division only)

3-man Obstacle (Youth & Adult divisions)

Limit 2 rides per horse

Entry: \$5 per class • \$5 cattle fee per class

S.H.O.W. Membership required

Join day of the show • membership valid through 12-31-11

- \$20 individual membership •
- \$30 family membership •
- \$15 young adult membership •

Membership form available at www.stockhorseofwisconsin.com

ORIGINAL COGGINS (AND COPY) REQUIRED

Contact Brandon Schopf at (920) 495-2280 for additional details

Stock Horse of Wisconsin Event Rules

SHOW Competition Divisions

Adult- Males and females ages 18 and older.

Youth- Males and females ages 17 and under.

EQUIPMENT AND ATTIRE

Equipment - Horses shall be shown in a western or like saddle. Silver equipment will not count over good clean, working equipment. Horses, of all ages, may be shown in a snaffle, bosal, or curb bit. No more than one finger is allowed between non-romal reins with curb bit. No fingers between the reins are allowed with a romal. Curb chains or straps must be at least ½ inch in width and must lie flat against the horse's chin. No wire curbs are permitted, regardless of the amount of padding or tape. Absolutely no iron will be permitted under the jaws. Prohibited equipment includes tie downs, gag bits, mechanical hackamores and running martingales. A judge may prohibit the use of any equipment deemed to be inhumane.

Attire - Riders shall wear protective headgear or western hats. Long-sleeved shirts and western boots. Western boot type must include a heel. The use of spurs and chaps shall be optional. Clothing should be neat and clean.

SCORING

No horse shall be disqualified except for illegal equipment or obvious lameness. A horse will be given credit for what it can do subject to a few standard deductions. Using two hands on a curb bit will result in a two point run content deduction per maneuver in all classes. Specific deductions are listed with each class.

POINT SYSTEM - The judge must place each class in its entirety. The judge should avoid ties, one-half points are permissible. Specific maneuvers will be designated by the judge to be tie breakers in a class. The tie breaker maneuvers will be made prior to the start of the class and so noted on score sheets for show secretary to use in breaking ties in the class. Every horse in the class is awarded one point for each horse they beat, plus one point. (Examples: In a twenty horse class, the first place horse gets twenty points and the twentieth place horse gets one point. In a ten horse class, the first place horse gets ten points and the tenth place horse gets one point. In a five horse class the winner gets five points and the last place horse gets one point.) This system will be used for any size class.

High Point - High point will be based on points accumulated at Stock Horse of Wisconsin shows throughout the season. Season fee is \$5. High Point ties will be broken by awarding the high point award to the horse/rider with the highest combined placings in the Trail class. If this doesn't break the tie, the other classes will be used in the following order; pleasure and reining.

ENTRY FEES

All participants must be members of Stock Horse of Wisconsin (if you are not, you may join the day of the show). Cost of entry to each class is \$5 per horse/rider combination.

STOCK HORSE OF WISCONSIN CLASSES

STOCK HORSE PLEASURE CLASS

This class serves to measure the ability of the horse to be functional and a pleasure to ride. Horses shall be shown individually at the walk, trot and lope in both directions.

Markers shall be setup to designate gait changes or called on the public address system. If the class is held inside of an arena, the pleasure course shall be setup to make approximately one circle of the arena in each direction. If open terrain is available, the class may be held outside an arena. The pattern may be started either in the left or right direction. The order of gaits shall be: 1) Walk 2) Trot 3) Extended Trot 4) Lope 5) Stop and Reverse 6) Walk 7) Lope 8) Extended Lope 9) Trot 10) Stop and Back. The extended trot may be ridden with the rider either posting or standing in the stirrups. The reverse may be executed in either direction.

Scoring - Each gait, including transitions, will be scored from 1 to 10. There will be 5 scores in each direction for a total of 10 scores and a maximum of 100 points for each horse's work. The scoring guide for each maneuver, including transitions, is as follows:

- 1 to 4 Points – Major faults such as wrong lead, broken gait, lack of control, failure to perform requested gait.
- 5 to 7 Points – Average quality of movement of gaits and transitions with some or no faults.
- 8 to 10 Points – High quality mover that is functionally correct in all gaits and transitions, well mannered and responsive, soft and cadenced in all gaits.

STOCK HORSE TRAIL

The trail class, as the name implies, tests the horse's ability to cope with many situations encountered in everyday ranch work. The horse is ridden through a pattern of obstacles and is judged on his ability to negotiate them correctly. It is important that the horse be asked to trot and lope during the event course.

No less than six and no more than eight obstacles will be used in this event. Obstacles may be placed in any order and location, however, obstacles should nearly approximate those found on the ranch during the course of everyday ranch work.

Show committees have the option of setting up the trail course to best fit their arena conditions. An outdoor course is recommended if appropriate terrain is available. Each single performance event can be time-consuming, especially with large classes, so it is imperative that time restrictions are placed on this class. The show committee, either through a pilot run or estimation, shall select a reasonable course that can be negotiated in a reasonable amount of time (4 minutes or less).

The actual trail course cannot be made available to exhibitors or posted prior to the day of competition. The course may be walked on foot, but no horses are allowed on trail course prior to competition. These rules also apply to outdoor courses. Outdoor courses may be observed on horseback, but no horse/rider exhibitors are allowed on the actual course until their trail run begins.

Obstacles- We believe that new obstacles may be added at any time, and we welcome any new and different tests which members may come up with, provided they can be found in everyday ranch work.

Following is a list of obstacles from which selections can be made, but not limited to: Open and close gate, walk over bridge, carry sack of feed, jump over obstacle, do side pass maneuver, walk over water obstacle, ground tie or hobble, pick-up feet, lead at the trot, walk through brush, swing rope, load in trailer, trot or lope over posts, step in and out of obstacle, put on slicker or coat, stand to mount, open gate on foot, rope dummy steer head, drag obstacle with rope through obstacle, and back through, in, or around selected areas.

- There are two mandatory obstacles: Opening and closing the gate (either afoot or horseback) and trailer loading and unloading.

All of these obstacles are not necessarily suitable to the Youth Division, notably the rope drag. Therefore, we recommend that a concern for the safety of Youth Exhibitors be a criteria in selecting obstacles for the Youth Division. If eight obstacles are used in the Adult and Youth Trail Class, one or two of these obstacles can be omitted for the Youth Division and still have the necessary six obstacles for the class.

Scoring - Each obstacle shall have a numerical score of 10, and the possible score for each obstacle shall be the same. Scoring is made on the ability of the horse to negotiate obstacles clean, correct, briskly and without undue hesitation. The rider has the option of eliminating any obstacle and taking a score of "0" for the missed obstacle. A judge may ask a horse to pass on an obstacle after three refusals or for safety concerns.

STOCK HORSE REINING

This class measures the ability of the western stock horse to perform many basic handling maneuvers. The horse should guide willingly without undue resistance. The Stock Horse of Texas Association has two recognized patterns. Pattern 1 requires a stop before beginning the spins. Pattern 2 requires a break to a walk or stop before executing the lope.

Scoring - The patterns are broken down into either 7 or 8 maneuvers to be scored 10 points each. Reduction in scores of 2 points per maneuver will be assessed for using 2 hands with a curb bit. Over or under spinning will reduce the score 2 points per maneuver. Maneuvers performed incorrectly or without any degree of difficulty will be scored accordingly. Kick out will reduce the score by 5 points per maneuver. Break of gait will reduce the score by 3 points per maneuver. Dragging our lead will reduce the score by 2 points per corner of the circle.

Pattern 1:

Mandatory Markers

The judge shall indicate with markers on arena fence the center of the pattern.

Ride pattern as follows:

1. Trot to center of arena and stop.
2. Complete three spins in each direction (first left then right).
3. Begin on right lead and lope two large circles to the right, change leads.
4. Lope two large circles to the left, change leads.
5. Begin a large circle to the right but do not close this circle. Run down the right side of the arena past the center marker and do a left roll back at least 20 feet from the wall or fence, no hesitation.

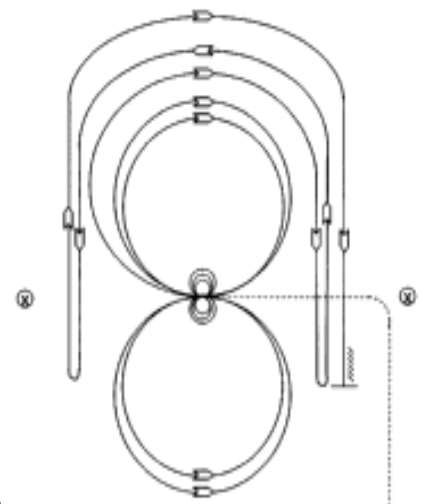

6. Continue back around the previous circle but do not close this circle. Run down the left side of the arena past the center marker and do a right roll back at least 20 feet from the wall or fence, no hesitation.
7. Continue back around previous circle but do not close this circle. Run down the right side of the arena past the center marker and do a sliding stop at least 20 feet from the wall or fence. Back up at least 10 feet. Hesitate to show completion of pattern.

Pattern 2:

Mandatory Marker Along Fence or Wall

The judge shall indicate with markers on arena fence or wall the center of pattern.

Ride pattern as follows:

1. Start by trotting into center of arena and either stop or walk before departure.
2. Make a large fast circle to right on the right lead.
3. Draw the second circle down to a small circle until you reach the center marker; stop.
4. Do two spins to the inside of the small circle at the center marker; at end of spins horse should be facing the left wall, slight hesitation.
5. Begin on left lead and make a large fast circle, then a small circle, again drawing it down to the center of the arena, stop, no hesitation on these stops.
6. Do two spins to the inside of the circle, slight hesitation, horse to be facing left wall.
7. Take a right lead and make a fast figure eight over the large circles, close the eight, and change leads.
8. Begin a large fast circle to the right but do not close this circle. Run down the right side of the arena past the marker and do a left roll back at least 20 feet from the wall or fence, no hesitation.
9. Continue back around the previous circle but do not close this circle. Run down the left side of the arena past the center and do a right roll back at least 20 feet from the wall or fence, no hesitation.
10. Continue back around previous circle, but do not close this circle. Run down the right side of the arena past the center marker and do a sliding stop at least 20 feet from the wall or fence. Back up at least 10 feet. Hesitate to show completion of pattern.

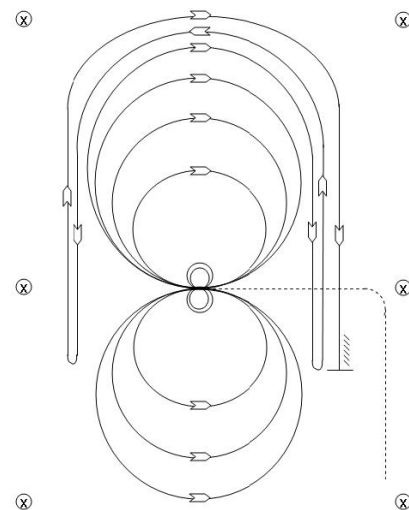

***NOTE – Roughing the livestock in all cattle classes will be grounds for disqualification.
This judgment will be made by members judging those classes.***

STOCK HORSE SORTING

This class will judge the team of two horse and rider's ability to sort and pen an individual cow in a controlled manner. The teams must be picked by the individuals and submitted prior to drawing for cattle. Each individual may ride twice but must pay for each ride.

There will be three classes divisions in this class, Adult, Youth and Combined. In the combined division, the team is made up of one youth and one adult. Placings in the combined division will not be considered for adult or youth high point.

Cattle will be drawn per horse/rider team out of a hat.

Scoring - This event will be timed and the shortest time is the winner. The time limit is 3 minutes. A break of gait from trot to lope is a 30 second penalty. Team may be disqualified, at the discretion of the judge, for poor stockmanship.

STOCK HORSE BREAKAWAY ROPING

This class will judge the horse and riders ability to walk into a group of cattle, pick their pre-drawn cow and rope it while being in control.

Scoring - This event will be timed and the shortest time is the winner. The time limit is 3 minutes. A break of gait from trot to lope is a 30 second penalty.

STOCK HORSE RANCH ROPING

This event is a three man ranch roping. The cow will be headed, heeled, pulled to the ground and the ropes placed on both front and hind feet. Each three man team has two minutes to head, four minutes to complete the run. Time stops when both ropes are tight and the ground man is off the calf.

The three man teams will be picked by draw out of a hat. Each horse/rider combination may enter themselves in the draw twice, and must pay for each ride.

Scoring - The shots will be scored based on degree of difficulty. The head score and the hind score will be added together for a final score provided the cow was taken to the ground. The fastest time will be the tiebreaker.

HEAD SHOTS

Del Viento/Turnover	14
Scoop	10
Houlihan/Backhand	10
Offside Overhand	8
Overhand	6

HEEL SHOTS

Contra-Viento	17
Del Viento	15
Backhand over hip	14
Backhand Strt. Behind hip	14
Forehand over hip	13
Scoop hip	13
Backhand hip	12
Strt. behind hip	12
Johnny Blocker Trap	10
Standard hip	10
Backhand trap	8
Overhand trap	6

OTHER

Completion under 1 minute	+3
Completion under 2 minutes	+2

DELETED POINTS

Missed Shots	-2
One heel	-1
Lost rope	-5
Rim Fire	DQ
Rope on saddle	DQ

Idlewild Farm



2339 Idlewild Road • Sturgeon Bay

From Green Bay take Highway 57 north 35 miles.

Watch for the junction of Highways 57 and 42.

Shortly after the junction, take a right on Idlewild Road

(first right after the highways merge - just past DeLeers Construction/Ambient Homes).

Idlewild Farms is the second place on the Right.

Area Motel/Hotels

Maritime Inn, 1001 North 14th Ave, Sturgeon Bay,
(920) 743-7231

Chal-A Motel, 3910 Highway 42/57, Sturgeon Bay
(920) 743-6788

AmericInn, 6225 Ashland Road, Sturgeon Bay
(920) 743-5898

Comfort Inn, 923 Green Bay Road, Sturgeon Bay
(920) 743-7846

Lipskys by the Bay, 6459 Hwy 57, Dykesville
(920) 866-2277

Visit www.stockhorseofwisconsin.com for additional lodging information